

ULTRA ARC TITAN

1400 WATT FOLLOWSPOT USER MANUAL

MODELS:

LONG THROW – UAT-LT-208/240

SHORT THROW – UAT-ST-208/240



Strong Lighting
10533 Chandler Rd, Suite 101
La Vista, NE 68128
U.S.A.
402-506-9096 TEL

www.strong.lighting

Strong Lighting
ULTRA ARC TITAN USER MANUAL

MODELS
UAT-LT-208/240 & UAT-ST-208/240

June 2020

<u>CONTENTS</u>	<u>PAGE</u>
LIMITED WARRANTY.....	2
CONTROL DESCRIPTIONS	
FOLLOW SPOT	3
INITIAL SET-UP AND OPERATION	4
LAMP INSTALLATION	6
LAMP POSITIONING DIAGRAM	6
FOLLOW SPOT OPERATION	7
OPTICAL SYSTEM OPERATION	
SET UP AND FOCUSING	7
BEAM CONTROL	7
TECHNICAL DATA	
LAMP	8
ELECTRICAL	8
MAINTENANCE	
LENS CLEANING	8
HOUSING REMOVAL AND LUBRICATION	9
TROUBLESHOOTING	9
REPLACEMENT PARTS LIST	10-12
SCHEMATIC.....	13

LIMITED WARRANTY

Thank you for purchasing the Strong Lighting Ultra Arc Titan.

The Strong Lighting Ultra Arc Titan is warranted against defects in material and workmanship for a period of one year from date of purchase from Strong Lighting. In case of difficulty, contact Strong Lighting or your dealer for repair or return instructions. Iris, dowser, and clipper are warranted for six months under normal use.

Lamps are excluded from this warranty. This warranty does not apply to mechanical defects caused by rough handling or to damage caused by improper operation not in accordance with this manual. Cause of defect is in the sole judgment of Strong Lighting .

This warranty is voidable at Strong Lighting's option under the following circumstances:

User makes unauthorized modifications (electrical or mechanical).

The unit is connected to improper voltage supply.

Any other condition occurs which causes catastrophic failure or impairs Strong Lighting's ability to render proper service.

If the unit is modified by the customer without permission, the customer agrees to pay for any time or parts necessary to remove the modifications before repair, if necessary.

Strong Lighting will not be responsible for consequential damages caused by failure for whatever reason of equipment of its manufacture. Sole liability is for equipment of its manufacture. Sole liability is for repair or replacement (at Strong Lighting's option) of the defective equipment under the terms described above.

CONTROL DESCRIPTION

FOLLOW SPOT

1. TWO POSITION MASTER SWITCH
Controls power to fans and Lamp Switch
Down = **Off**
Up = **ON**
2. FUSE
15 Amp 3AB
3. TWO POSITION LAMP SWITCH
Turns lamp on and off
4. HOUR METER
Records operating time accumulated on lamp. Non-resettable.
5. REAR LENS CONTROL HANDLE
Used to focus image. Turn handle clockwise to lock and counter-clockwise to unlock. Slide handle to focus beam. Changes image size. Turn handle clockwise to lock and counter-clockwise to unlock.
6. FRONT LENS CONTROL HANDLE
Used to change image size. Slide handle forward for smaller image, "spot" for longer throws. Slide back for larger image, "flood" for shorter short throws.
7. DOWSER
Mechanical dimmer. Open when lever is moved towards operator.
8. CLIPPER
Masks spot to rectangular strip. Open when lever is moved towards operator.
9. IRIS
Opens widest when lever is moved towards operator. **WARNING:** Iris left in closed position with dowsers open for extended time may cause non-warranty damage to Iris.
10. COLOR BOOMERANG
Color Gel or diffusion is inserted into beam when lever is moved up. Six controls plus a release handle.
11. TILT LOCK KNOB
Friction lock for vertical tilt of unit.
12. POWER CORD
Connect to 208-240 volt service. Plug not supplied
13. REAR ACCESS DOOR
Gives operator access to lamp adjustment screws.

INITIAL SET-UP AND OPERATION

1. Unpack carefully and inspect for shipping damage.
2. Unfold the four Base Legs by removing the top bolt and nut from each leg. Will need 9/16 open end wrench and socket. Orient the legs with the leveling feet and casters facing down. (See Collapsible Base Assembly Instruction Diagram on page 5).
3. Insert yoke into column.
4. Attach Pan Drag mechanism to column with screws provided. Will need 5/32 Allen wrench.
5. Install tilt lock knobs on either side of the bail so 3/4" of thread is showing. Position large fiber washer nearest the bail making sure the brass bushing is installed. Large metal washer is positioned closest to handle.
6. Lift the Ultra Arc Titan using the front and rear of the chassis. Position the bail handle shafts in the U-shaped slots at the top of the yoke. Ensure that the washers are positioned properly and that the bushing is in the slot. Turn the tilt lock knobs to tighten the grip on the yoke.
7. Unscrew the four thumbscrews on either side of the color boomerang.
8. Insert gel, cover with ring and secure with supplied screws.
9. Lower left-hand (operator right) gel holder and raise the next one.
10. Repeat steps #8. To access the bottom gel holder, raise all the gels to the left or right and lower the one being worked on.
11. As you move toward the right-hand gels (operator left), insert progressively lighter colors. The left hand (operator right) holder should be used for deep blue or purple colors). This will prolong their life.
12. Place the color boomerang on top of the Ultra Arc Titan with the lever handles facing the other operation controls. Secure with four thumbscrew near the bottom of the housing.

COLLAPSIBLE BASE ASSEMBLY INSTRUCTION DIAGRAM

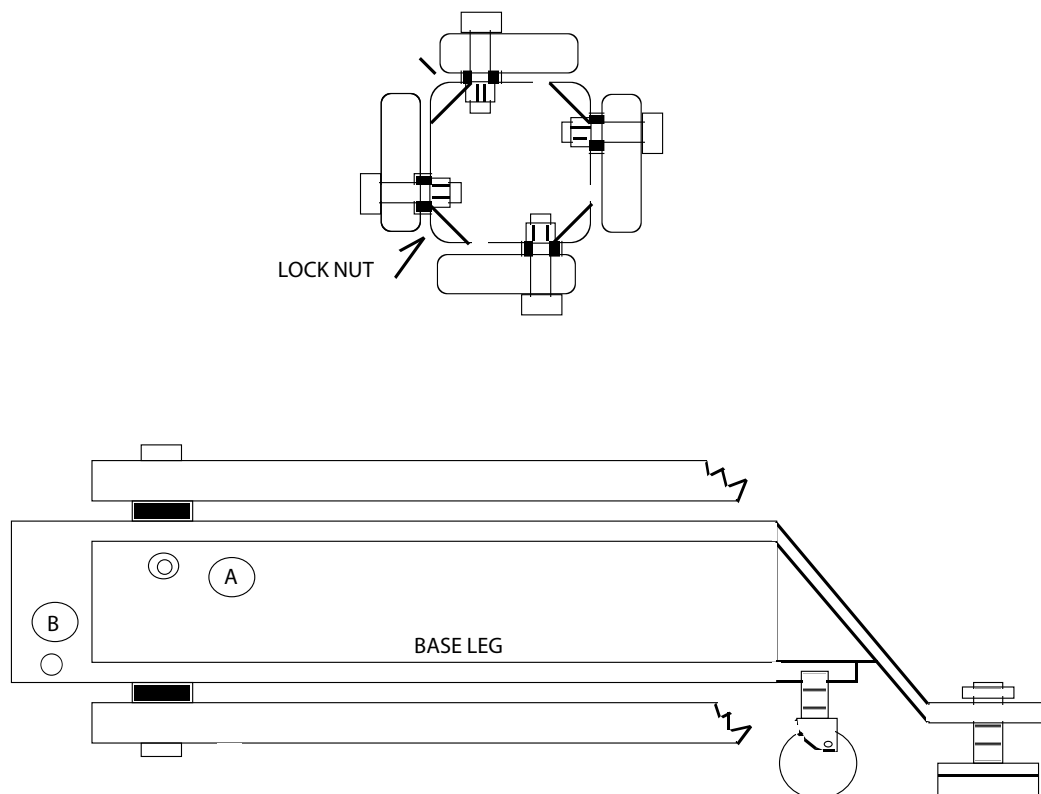

1. Insert bolt through hole "A" on the main base tube.
Position hole "A" on the base leg over the bolt in the main base tube.
Slide the base leg over the bolt and secure with Nyloc nut.

NOTE: Nyloc nut should be secured on inside of the base leg. (See diagram above).

2. Repeat steps above for remaining base legs.

LAMP INSTALLATION

1. Unplug unit from power source before attempting lamp installation.
2. Remove rear cover. Remove/loosen four thumbscrews on rear of cover, lift the rear cover straight up.
3. Open Rear Access Door. Remove HTI 1400 lamp (not supplied with the unit) from packing materials. Do not touch the glass. Follow manufacturer's handling instructions. Pass lamp through the hole in the lamp adjustment plate and carefully align with Loc-it socket. Once lamp is engaged with socket turn lamp 90 degrees to the right as view from the back of the light until an audible click is heard. (See diagram below).
4. Replace/tighten rear cover and replace thumbscrews.

LAMP POSITIONING DIAGRAM

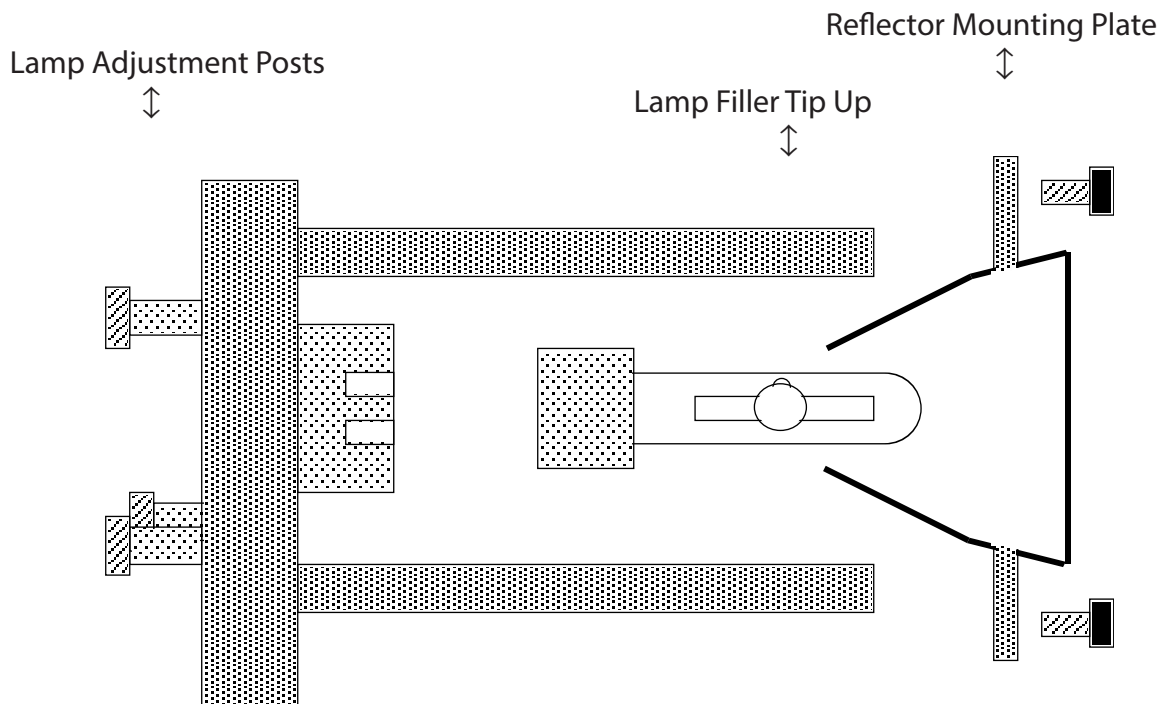

FOLLOWSPOT OPERATION

1. Connect followspot to 208/240 volt power source. Turn MASTER switch to the "ON" position (fans will power on). Be sure all fans are operating properly before flipping LAMP switch to "ON" position. The lamp should strike and warm up to full output within two minutes. If lamp does not light try cycling the LAMP switch OFF and then ON. If power is interrupted, lamp will go out. Allow two to three minutes with fan on before attempting a re-strike.
2. To maximize lamp life turn keep MASTER switch "ON" to power fans only for at least five minute after each use.
3. Dowser, iris and clipper are controlled by the ball knobs on top.
4. The front lens control handle (on lower side) is set for desired throw by sliding it forward for a narrow beam (long throw) or rearward for a wide beam (short throw). It may be locked in place by turning it clockwise. Do not over tighten!
5. The rear lens control handle (side of unit, near middle is used to obtain the desired focus, soft or hard edge. Slide it forward for wide beam (short throw) or backward for a narrow beam (long throw). It may be locked in position by turning clockwise. Do not over tighten!
6. To obtain desired throw at a given distance, both lenses must be moved. Lens position may be marked on the side of the unit.

OPTICAL SYSTEM OPERATION

I. SET UP AND FOCUSING

1. Move iris, dowser, and clipper controls toward operator to open.
2. Move front lens forward for spot or rearward for flood distribution. Position can be marked on side of chassis near handle set.
3. Move rear lens until edge of pattern is in focus. Position may be adjusted hard or soft edge.
4. Close down the iris by moving its control handle away from the operator.
5. Focus may change slightly with iris closed. Best focus setting is with iris half open.
6. To "zoom" the lenses to a new position, a coordinated motion of both front and rear lenses is used. Note that these lenses move opposite of each other to maintain focus.

II. BEAM CONTROL

1. The dowser is a mechanical dimmer. The rear control handle is moved away to close and toward to open.
2. The clipper shapes the image to a strip or a rectangle of variable height. Move the middle control handle away to close and toward to open the clipper.

3. The iris provides a 6 to 1 change in image diameter. It is controlled by the front handle, away to close and toward to open. The brightest spot is obtained with the iris open and the lenses adjusted for the largest spot desired. Smaller spots are obtained using the iris.

WARNING: Iris left in closed position with dowsers open for extended time may cause damage to the iris.

TECHNICAL DATA

I. LAMP

The Ultra Arc Titan uses a Osram HTI 1400 W lamp. The light from an HTI discharge lamp is generated by an arc discharge with special chemical filling materials to achieve a color temperature of 6000 K.

The Osram HTI 1400 W has a rated life of 750 hours. Osram recommends you replace the lamp when operated more than 25% past their published rated service life.

HTI lamps emit ultra-violet radiation. For health reasons, they must always be enclosed when operated. If you are transporting the fixture for long distances, remove the lamp from fixture and send separately in a vibration proof packaging.

The lamps filler tip should always be above the discharge, otherwise there is a risk of a "cold" spot developing inside the discharge chamber where the filler substances may condense and change the photometric properties.

Replacement lamps are available from Osram lamp distributors as well as from Strong Lighting.

The lamp is cooled by a fan located below the lamp. This fan is essential to lamp operation. Improper cooling will cause decreased life and arc instability or color shift.

II. ELECTRICAL

The Ultra Arc Titan operates on 208 to 240 Volt 50/60Hz AC at 15 Amps.

MAINTENANCE

I. LENS CLEANING

1. Disconnect unit from power source before attempting any maintenance.
2. Remove rear housing, unplug white electrical connector (for Hour Meter) attached to front housing. Remove the three control knobs and then the front housing.
3. Clean all lenses using a good quality glass cleaner and a soft, lint-free cloth.
4. Clean reflector if necessary. Blow off dust first. Use denatured alcohol and a lint free cloth for final cleaning. The reflector has been coated with a delicate high reflective coating and will scratch easily if not cleaned properly.
5. Replace front housing. Reconnect Hour Meter. Reconnect the three control knobs.
6. Replace rear housing and tighten all thumbscrews.

II. HOUSING AND LUBRICATION

1. Disconnect unit from power source before attempting servicing.
2. Unscrew the three control knobs on top of unit and remove.
3. Unscrew the thumbscrews on the front and rear housing.
4. Remove rear housing (see lamp installation on page 6).
5. Unplug white connector (for Hour Meter) to front housing.
6. Tighten vertical tilt lock knobs on either side of yoke (unit will be unbalanced with housing off).
7. Grip housing at front and rear top edges.
8. Lift straight up until front lens is cleared, and remove.
9. Wipe all four bearing shafts with a cloth dampened with light furniture wax (Pledge). Avoid excess wax.
10. Operate front and rear lenses forward and back to distribute wax.

III. TROUBLESHOOTING – LAMP AND BALLAST (ELECTRICAL)

1. If fan fails to run, check power and fuse. Replace fuse with 15 amp 3AB fuse.
2. If fan runs and lamp does not strike.
 - A. Check to ensure that the lamp is firmly seated in its socket and all electrical connections are secure. Make sure that the lamp has not reached the end of its life. If so, replace the lamp.
 - B. If the new lamp does not strike, check line voltages. Lamps may not start with power line below 208 volts.
3. If the above measures have not been successful, call your distributor or Strong Lighting for further assistance.

Replacement Parts Price List:
UAT-LT-208/240, UAT-ST-208/240

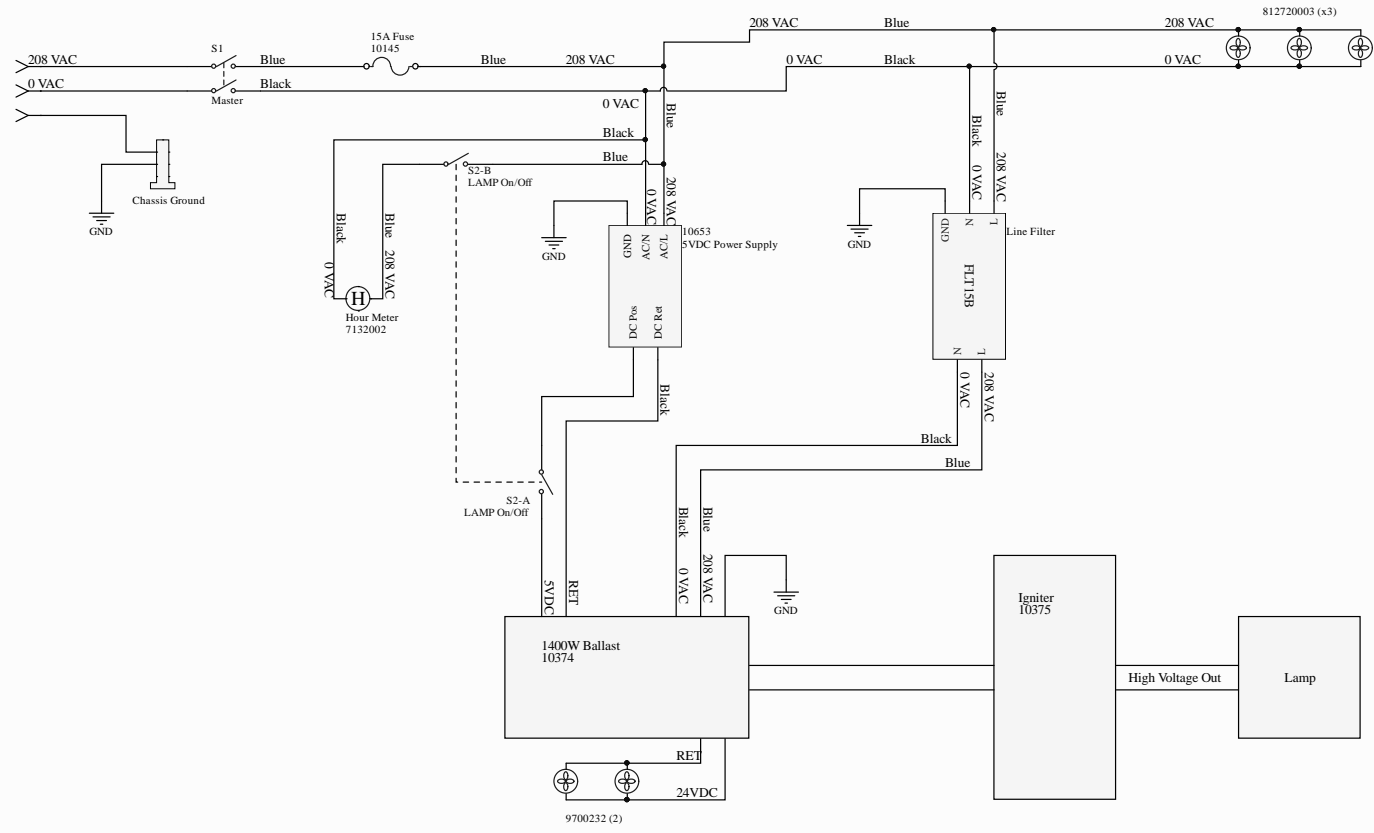

Title Titan Long Throw			Strong Lighting 10533 Chandler Rd Suite 101 La Vista, NE 68128 402.506.9096	
Size: Tablet	Num: 12047	Rev: 1	Date: 7/7/2020	Time: 11:39:00 AM
Author: A. Erich Sawyer		Approved by: Paul Rabinovitz		Approved date: *



WARRANTY CARD

Please Print

MODEL NUMBER(S) _____

SERIAL NUMBER(S) _____

DATE OF PURCHASE _____

PLACE OF PURCHASE _____

(DEALER NAME) _____

USER'S NAME _____

COMPANY NAME _____

STREET ADDRESS _____

CITY / STATE / ZIP _____

TELEPHONE _____

FAX _____



Please fold along the dotted lines and staple
with return address on the outside as shown above.
Thank you!

Place
Stamp
Here

Strong Lighting
10533 Chandler Rd, Suite 101
La Vista, NE 68128

ATTENTION: WARRANTY DEPARTMENT